

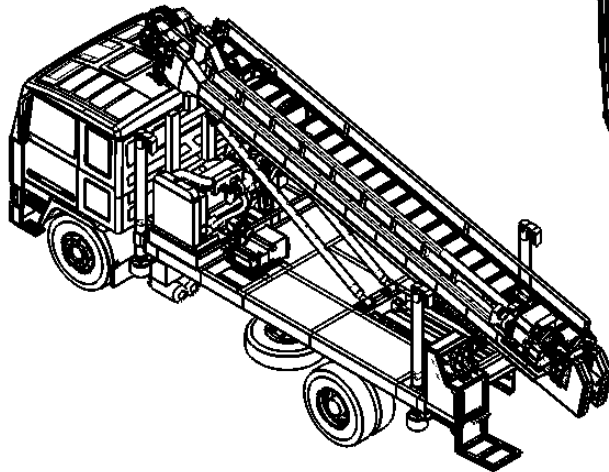

Nota: Usar tabla 7168 grado fino, para cotas sin tolerancia

DIN 7168	TOLERANCIAS MEDIDAS EN MM.						TOLERANCIAS ANGULARES DEGRADO			
	1-6	6-30	30-100	100-300	300-1000	1000-2000	10'	10'-30'	30'-100'	100'-
FINO	$\pm 0,05$	$\pm 0,1$	$\pm 0,15$	$\pm 0,2$	$\pm 0,3$	$\pm 0,5$				
MEDIO	$\pm 0,1$	$\pm 0,2$	$\pm 0,3$	$\pm 0,4$	$\pm 0,6$	$\pm 1,0$	$\pm 1'$	$\pm 30'$	$\pm 20'$	$\pm 10'$
GRUO	$\pm 0,2$	$\pm 0,5$	$\pm 0,8$	$\pm 1,2$	$\pm 2,0$	$\pm 3,0$				

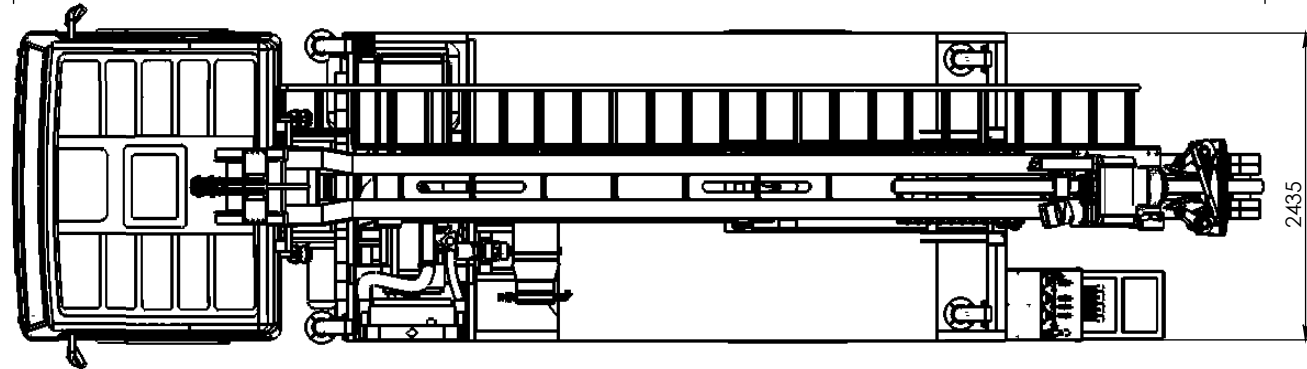
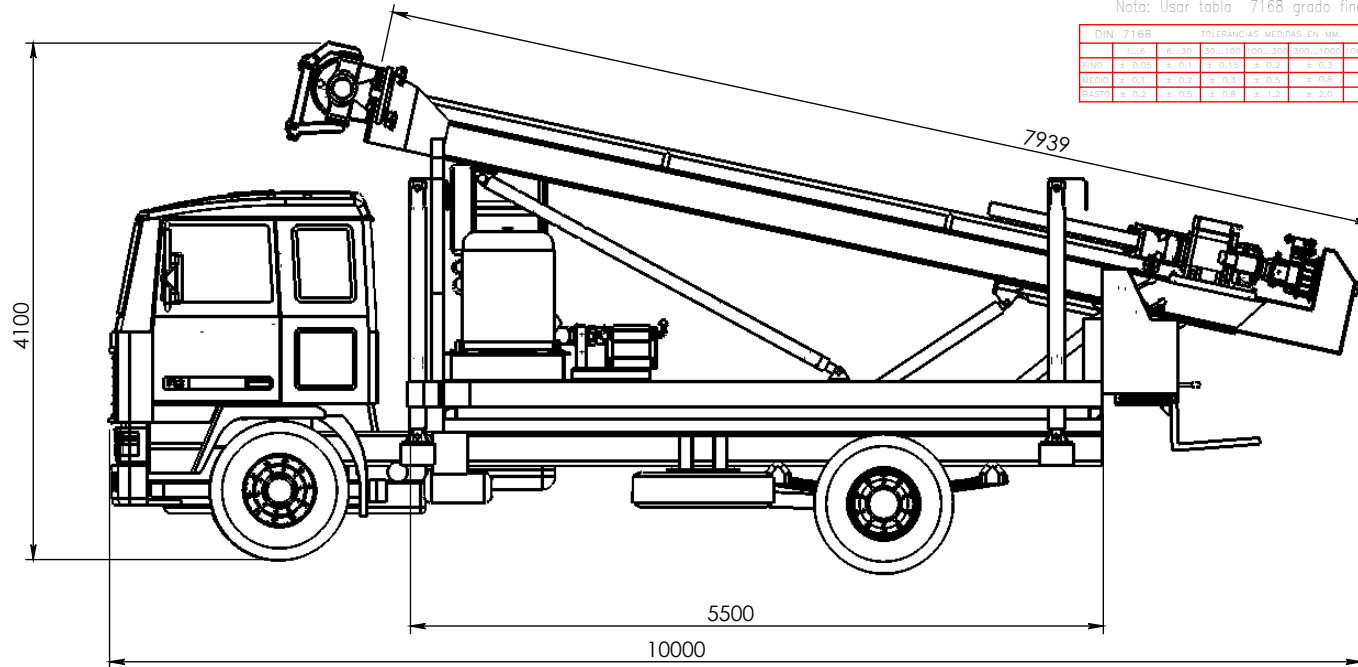
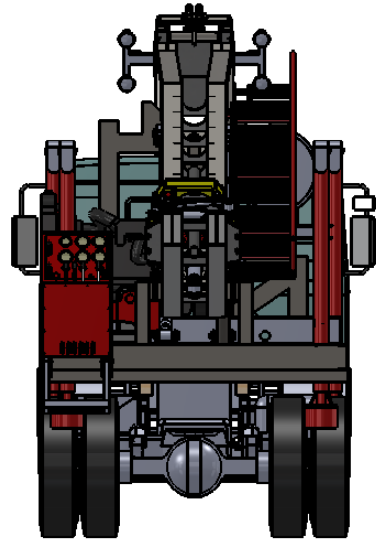
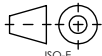

MATERIAL:			TRAT TERM:		CANT: 01
	NOMBRE	FECHA	FIRMA		ESCALA 1:200
PROYECTO	C. Rojas	19/04/11			
DIBUJO	J. Morales	19/04/11			
REVISO	C. Rojas	19/04/11			
HOJA 1 / 1	Nº PARTE CONJUNTO 00	DEEP GOLD 1500 SC PLANO 3 VISTAS			REVISIÓN A